

INSERTO H570T

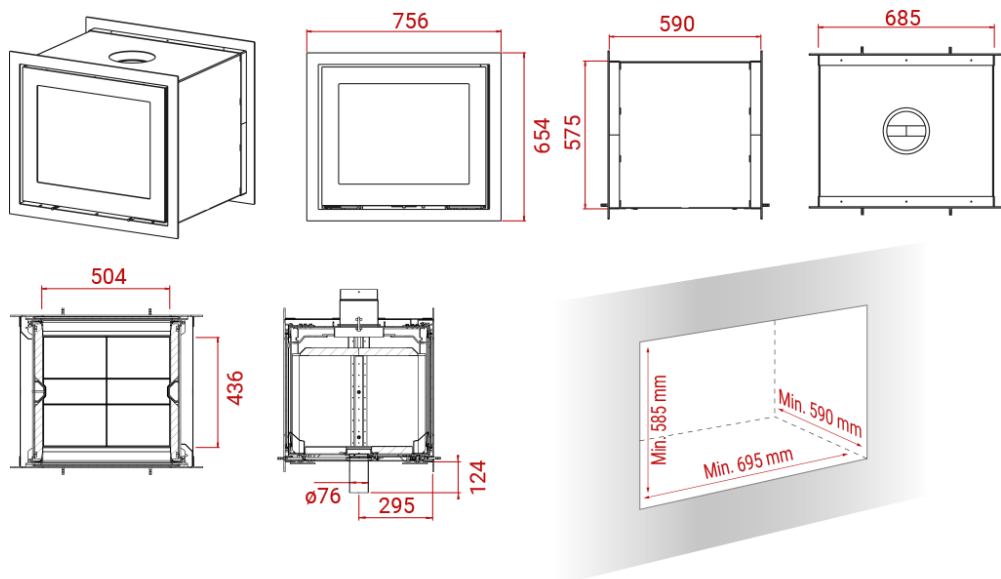

Peso 155 kg



Area riscaldata
30-130 mq



Depressione fumi
12 Pa



Polveri sottili
29 mg/m³



Potenza nominale
6 kW



Consumo orario
2 kg



Potenza di esercizio
4-9 kW



Rendimento
80,5%